



Your new Binks spray gun is exceptionally rugged in construction, and is built to stand up under hard, continuous use. However, like any other fine precision instrument, its most efficient operation depends on a knowledge of its construction, operation, and maintenance. Properly handled and cared for, it will produce beautiful, uniform finishing results long after other spray guns have worn out.

TYPES OF INSTALLATION

SIPHON FEED CUP HOOKUP

Air pressure for atomization is regulated at extractor. The amount of fluid is adjusted by fluid control screw on gun, viscosity of paint, and air pressure (see figure 1).

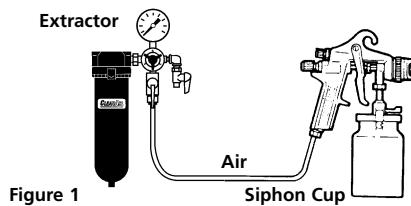

Figure 1

PRESSURE FEED CUP HOOKUP

For fine finishing with limited spraying.

Air pressure for atomization is regulated at extractor; fluid pressure at cup regulator. For heavy fluids and internal mix nozzle spraying, fluid adjusted by control screw on gun.

Pressure cup also available less regulator (see figure 2).

Oil & Water Extractor

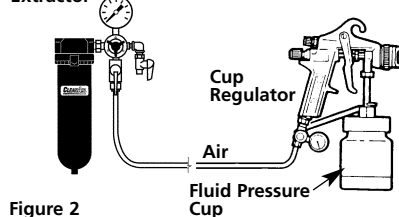

Figure 2

Extractor

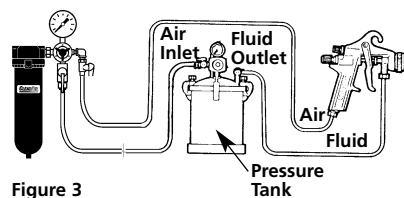

Figure 3

PRESSURE FEED TANK HOOKUP

For medium production spraying (single regulator).

Air pressure for atomization is regulated at extractor, fluid pressure at tank regulator (see figure 3).

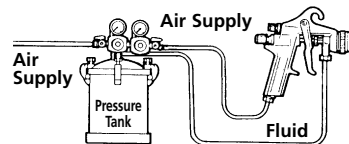

Figure 4

PRESSURE FEED TANK HOOKUP

For portable painting operations (double regulator).

Air pressure for atomization and fluid supply is regulated by two individual air regulators on tank (see figure 4).

PRESSURE FEED CIRCULATING HOOKUP

For heavy production spraying.

Air pressure atomization regulated at extractor. Fluid pressure regulated at fluid regulator (see figure 5).

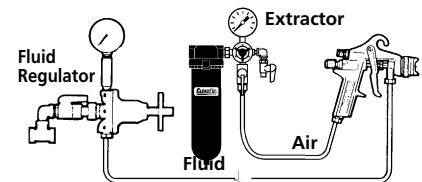

Figure 5

In this part sheet, the words **WARNING**, **CAUTION** and **NOTE** are used to emphasize important safety information as follows:

⚠ WARNING
 Hazards or unsafe practices which could result in severe personal injury, death or substantial property damage.

⚠ CAUTION
 Hazards or unsafe practices which could result in minor personal injury, product or property damage.

NOTE
 Important installation, operation or maintenance information.

⚠ WARNING

Read the following warnings before using this equipment.

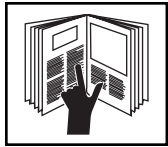

READ THE MANUAL
 Before operating finishing equipment, read and understand all safety, operation and maintenance information provided in the operation manual.



WEAR SAFETY GLASSES
 Failure to wear safety glasses with side shields could result in serious eye injury or blindness.



DE-ENERGIZE, DEPRESSURIZE, DISCONNECT AND LOCK OUT ALL POWER SOURCES DURING MAINTENANCE
 Failure to De-energize, disconnect and lock out all power supplies before performing equipment maintenance could cause serious injury or death.



OPERATOR TRAINING
 All personnel must be trained before operating finishing equipment.



EQUIPMENT MISUSE HAZARD
 Equipment misuse can cause the equipment to rupture, malfunction, or start unexpectedly and result in serious injury.

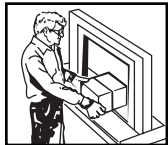

KEEP EQUIPMENT GUARDS IN PLACE
 Do not operate the equipment if the safety devices have been removed.

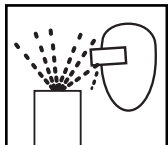

PROJECTILE HAZARD
 You may be injured by venting liquids or gases that are released under pressure, or flying debris.

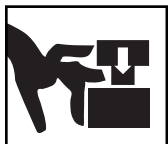

PINCH POINT HAZARD
 Moving parts can crush and cut. Pinch points are basically any areas where there are moving parts.



AUTOMATIC EQUIPMENT
 Automatic equipment may start suddenly without warning.



INSPECT THE EQUIPMENT DAILY
 Inspect the equipment for worn or broken parts on a daily basis. Do not operate the equipment if you are uncertain about its condition.



NEVER MODIFY THE EQUIPMENT
 Do not modify the equipment unless the manufacturer provides written approval.



KNOW WHERE AND HOW TO SHUT OFF THE EQUIPMENT IN CASE OF AN EMERGENCY



PRESSURE RELIEF PROCEDURE
 Always follow the pressure relief procedure in the equipment instruction manual.



NOISE HAZARD
 You may be injured by loud noise. Hearing protection may be required when using this equipment.



STATIC CHARGE
 Fluid may develop a static charge that must be dissipated through proper grounding of the equipment, objects to be sprayed and all other electrically conductive objects in the dispensing area. Improper grounding or sparks can cause a hazardous condition and result in fire, explosion or electric shock and other serious injury.



FIRE AND EXPLOSION HAZARD
 Never use 1,1,1-trichloroethane, methylene chloride, other halogenated hydrocarbon solvents or fluids containing such solvents in equipment with aluminum wetted parts. Such use could result in a serious chemical reaction, with the possibility of explosion. Consult your fluid suppliers to ensure that the fluids being used are compatible with aluminum parts.



TOXIC FLUID & FUMES
 Hazardous fluid or toxic fumes can cause serious injury or death if splashed in the eyes or on the skin, inhaled, injected or swallowed. LEARN and KNOW the specific hazards of the fluids you are using.



WEAR RESPIRATOR
 Toxic fumes can cause serious injury or death if inhaled. Wear a respirator as recommended by the fluid and solvent manufacturer's Material Safety Data Sheet.

FOR FURTHER SAFETY INFORMATION REGARDING BINKS AND DEVILBISS EQUIPMENT, SEE THE GENERAL EQUIPMENT SAFETY BOOKLET (77-5300).

Binks MODEL 7 SPRAY GUN

GUN HANDLING

The first requirement for a good resultant finish is the proper handling of the gun. The gun should be held perpendicular to the surface being covered and moved parallel with it. The stroke should be started before the trigger is pulled and the trigger should be released before the stroke is ended. This gives accurate control of the gun and material.

The distance between gun and surface should be 6 to 12 inches depending on material and atomizing pressure. The material deposited should always be even and wet. Lap each stroke over the preceding stroke to obtain a uniform finish.

NOTE

To reduce overspray and obtain maximum efficiency, always spray with the lowest possible atomizing air pressure.

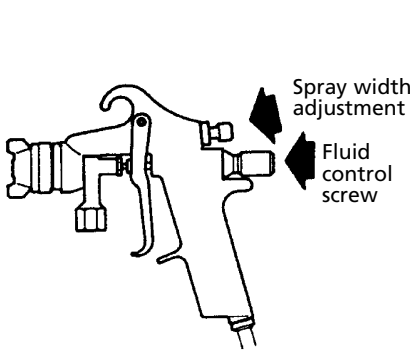
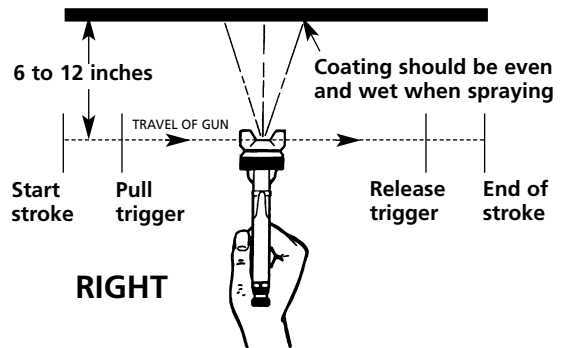
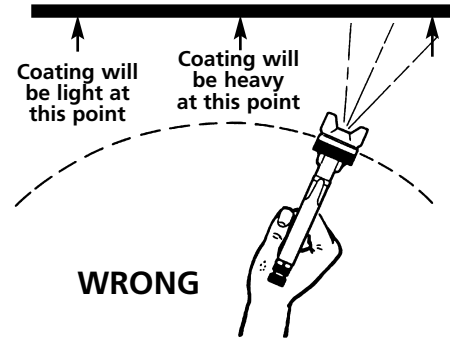

Spray width adjustment: Turn clockwise for round, counterclockwise for fan.

Fluid control screw: Turn clockwise to decrease flow, counterclockwise to increase flow.

As width of spray is increased, more material must be allowed to pass through the gun to obtain the same coverage on the increased area.

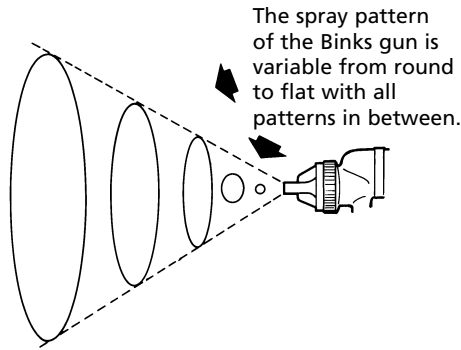

SIPHON SPRAYING

Set atomization pressure at approximately 50 PSI for lacquer and 60 PSI for enamel. Test spray. If the spray is too fine, reduce the air pressure or open fluid control screw. If the spray is too coarse, close the fluid control screw. Adjust the pattern width and repeat adjustment of spray if necessary.

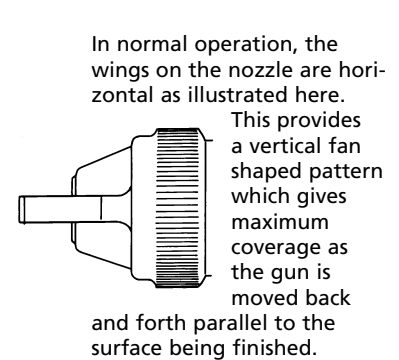

In normal operation, the wings on the nozzle are horizontal as illustrated here.

This provides a vertical fan shaped pattern which gives maximum coverage as the gun is moved back and forth parallel to the surface being finished.

PRESSURE SPRAYING



After selecting correct size fluid orifice, set fluid pressure for desired flow. Open atomization air and test spray. If spray is too fine, reduce air pressure. If spray is too coarse, raise air pressure. Adjust pattern width and repeat adjustment of spray.

Keeping fluid control screw in open position will reduce fluid needle wear.

NOTE

To reduce overspray and obtain maximum efficiency, always spray with the lowest possible atomizing air pressure.

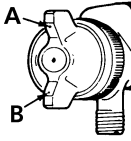
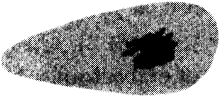
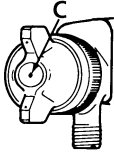
FAULTY PATTERNS AND HOW TO CORRECT THEM

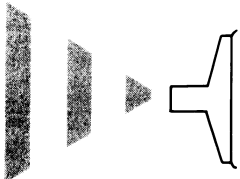
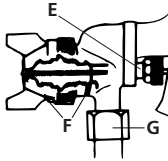
PATTERN	CAUSE	CORRECTION
	<p>Dried material in side-port "A" restricts passage of air. Greater flow of air from cleaner side-port "B" forces fan pattern in direction of clogged side.</p> 	<p>Dissolve material in side-ports with thinner, then blow gun clean. Do not poke into openings with metal instruments.</p>
	<p>Dried material around the outside of the fluid nozzle tip at position "C" restricts the passage of atomizing air at one point through the center opening of air nozzle and results in pattern shown. This pattern can also be caused by a loose air nozzle.</p> 	<p>Remove air nozzle and wipe off fluid tip using rag wet with thinner. Tighten air nozzle.</p>
	<p>A split spray or one that is heavy on each end of a fan pattern and weak in the middle is usually caused by:</p> <ol style="list-style-type: none"> (1) Too high an atomization air pressure (2) Attempting to get too wide a spray pattern with thin material. 	<p>Reducing air pressure will correct cause (1). To correct cause (2), open material control to full position by turning to left. At the same time, turn spray width adjustment to right. This will reduce width of spray, but will correct split spray pattern.</p>
	<ol style="list-style-type: none"> (1) Dried out packing around material needle valve permits air to get into fluid passageway. This results in spitting. (2) Dirt between fluid nozzle seat and body or loosely installed fluid nozzle will make gun spit. (3) A loose or defective swivel nut on siphon cup or material hose can cause spitting. 	 <p>To correct cause (1) back up knurled nut (E), place two drops of gun lube on packing, replace nut and tighten with fingers only. In aggravated cases, replace packing.</p> <p>To correct cause (2), remove fluid nozzle (F), clean back of nozzle and nozzle seat in gun body using rag wet with thinner, replace nozzle and draw up tightly against body.</p> <p>To correct cause (3), tighten or replace swivel nut.</p>

Binks MODEL 7 SPRAY GUN GENERAL MAINTENANCE

SPRAY GUN

1. Immerse only the front end of the gun until solvent just covers the fluid connection.
2. Use a bristle brush and solvent to wash off accumulated paint.
3. Do not submerge the entire spray gun in solvent because:
 - a. the lubricant in the leather packings will dissolve and the packings will dry out.
 - b. the lubricant at wear surfaces will dissolve causing harder operation and faster wear.
 - c. residue from dirty solvent may clog the narrow air passages in the gun.
4. Wipe down the outside of the gun with solvent-dampened rag.
5. Lubricate gun daily. Use a light machine oil on:

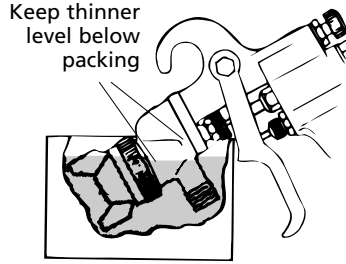

AIR NOZZLE, FLUID NOZZLE, NEEDLE

1. All nozzles and needles are precision made. They should be handled with care.
2. Do not make any alterations in the gun. To do so could cause finishing difficulties.
3. To clean nozzles, soak them in solvent to dissolve any dried material, then blow them clean with air.
4. Do not probe any of the holes in the nozzles with metal instruments. If probing is necessary, use only a tool that is softer than brass.

CAUTION

Never use lubricants containing silicone since these lubricants can cause finish defects.

- a. fluid needle packing.
 - b. air valve packing.
 - c. side port control packing.
 - d. trigger pivot point.
- Coat the fluid control spring with vaseline.

NOTE

All parts on a spray gun should be screwed in hand tight at first; this will avoid the possibility of cross threading the parts. If the parts can not be turned by hand easily, make sure you have the correct parts, unscrew, realign, and try again. NEVER use undue force in mating parts.

POINTERS ON CLEANING

When Used With Siphon Cup

A compatible thinner or solvent should be siphoned through gun by inserting tube in open container of that liquid. Trigger gun repeatedly to flush passageway thoroughly and to clean tip of needle.

When local codes prohibit spraying of thinner or solvent, use a gun washer to clean spray guns.

When Used With Pressure Tank

Shut off air supply to tank and release pressure on tank. Open vent and loosen air nozzle. Hold a piece of cloth over the air nozzle and squeeze trigger. Air will back up through fluid nozzle, and force fluid out of hose into tank. Next, put enough thinner into tank to wash hose and gun thoroughly. Spray thinner through the gun until it is clean. Attach fluid hose to air line and blow it out thoroughly to remove all traces of materials and to dry it.

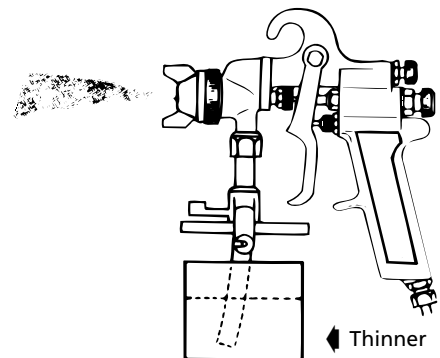

Binks MODEL 7 SPRAY GUN

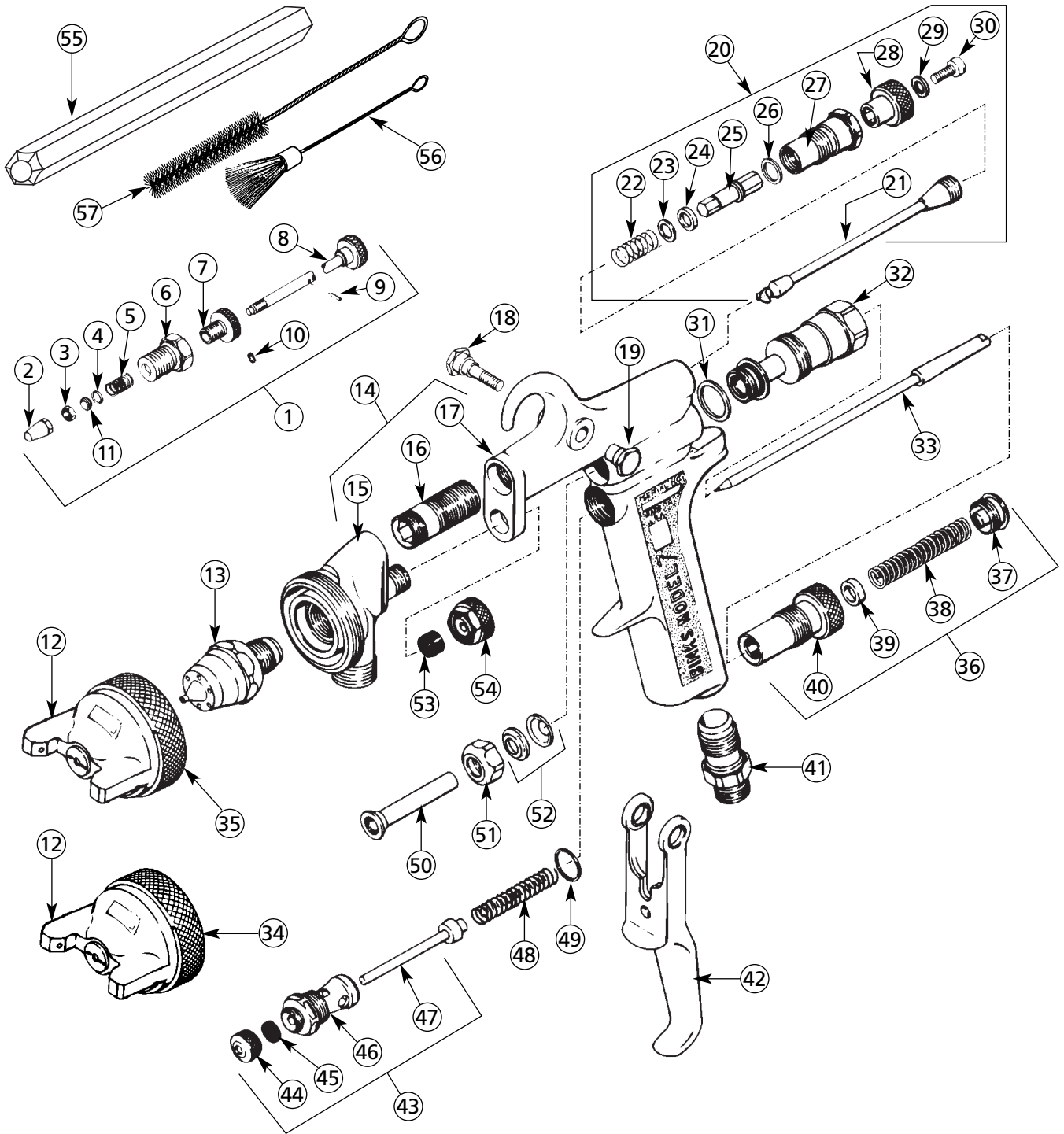

PARTS LIST

When ordering, please specify Part No.

ITEM NO.	PART NO.	DESCRIPTION	QTY.	ITEM NO.	PART NO.	DESCRIPTION	QTY.
1	54-1989◆	SIDE PORT CONTROL ASSEMBLY ..	1	34	†	RING.....	1
2	54-1986●	TIP	1	35	54-704††★	RING.....	1
3	54-1808★	LOCKNUT	1	36	54-724★	FLUID CONTROL ASSEMBLY.....	1
4	55-634★	RING	1	37	54-725●	SCREW.....	1
5	54-1804●★	SPRING.....	1	38	54-728-5■□●	SPRING.....	1
6	54-1794	BODY.....	1	39	54-727●	RING	1
7	54-1790	ADJUSTING PIN.....	1	40	54-726●	BODY.....	1
8	54-1988●★	STEM	1	41	54-768★	CONNECTION	1
9	84-95●	PIN	1	42	54-753★	TRIGGER	1
10	20-3593●	SCREW.....	1	43	54-1341	AIR VALVE ASSEMBLY.....	1
11	55-541-5□●★	PACKING	1	44	54-1340	NUT	1
12	*	AIR NOZZLE.....	1	45	54-747-5■□	PACKING (Kit of 5)	1
13	*	FLUID NOZZLE.....	1	46	54-751★	BODY.....	1
14	54-706●	HEAD AND BODY ASSEMBLY	1	47	54-744■★	STEM	1
15	54-707★	HEAD	1	48	54-750-5■□●	SPRING.....	1
16	54-710★	SCREW.....	1	49	54-749-5■□	GASKET	1
17	54-711●	BODY.....	1	50	54-718★	SLEEVE.....	1
18	54-759■★	SCREW Trigger	1	51	54-721★	RETAINER.....	1
19	54-760■★	STUD Trigger	1	52	54-722-5■□	WIPER	2
20	54-729★	SIDE PORT CONTROL ASSEMBLY ..	1	53	54-764-5■□	PACKING	1
21	54-730★	STEM	1	54	54-765★	NUT	1
22	54-736■●	SPRING.....	1	55	73-165◆	WRENCH Gunhead (Optional)	1
23	54-737★	WASHER	1	56	82-221	BRUSH	1
24	54-738-5■□	PACKING (Kit of 5)	1	57	82-469	BRUSH	1
25	54-735★	SPINDLE.....	1				
26	54-739■★	GASKET	1				
27	54-734★	HOUSING.....	1				
28	54-740★	KNOB.....	1				
29	54-742●	WASHER	1				
30	54-741-5□★	SCREW.....	1				
31	54-723-5■□	GASKET	1				
32	54-717★	HOUSING	1				
33	**	NEEDLE VALVE	1				

- * When ordering, please specify number stamped on nozzle.
- ** When ordering, please specify number stamped on needle stem.
- † Furnished with nozzle. See Nozzle Chart.
- †† Not Furnished with nozzle. Please order separately. See Nozzle Chart.
- Available in Repair Kit 6-188. Please order separately.
- Items **NOT** available separately.
- ◆ Optional. Please order separately.
- Available only as a quantity pack.
- ★ Available from Industrial Finishing distributors only.

NOZZLE AND NEEDLE SELECTION CHART

TYPE OF FLUID VISCOSITY TO BE SPRAYED	FLUID x AIR NOZZLES†	NOZZLE TYPE ††	CFM AT			MAX. PATTERN AT 8"	FLUID◆ NEEDLE	AIR NOZZLE RETAINING RING
			30 PSI	50 PSI	70 PSI			
THIN Sealers, Lacquers, Primers, Stains, Zinc Chromates, Lubricants	33SS x 33PM	PE	10.1	15.0	20.0	10.0"	33	54-704*
	36SS x 36SD	SE	7.8	11.5	—	10.0"	36	**
MEDIUM Lacquers, Enamels, Varnishes, Shellacs, Primers, Epoxies, Urethanes, Lubricants	36SS x 36SD	SE	7.8	11.5	—	10.0"	36	**
	36SS x 36SK	SE	11.5	15.7	20.2	13.0"	36	**
MEDIUM HEAVY House Paint, Multicolors, Wrinkles	38SS x 38PM	PE	9.3	14.9	20.0	10.0"	38	**

- † Fluid nozzle available in stainless steel. Please specify when ordering.
- †† PE Pressure feed, external mix. SE Siphon feed, external mix.
- * Not furnished with nozzle. Please order separately.
- ** Furnished with nozzle.
- ◆ All needles are stainless steel.

FLUID NOZZLE	33SS	33BSS	36SS	38SS
ORIFICE SIZE	.040	.046	.070	.086

AIR SUPPLY

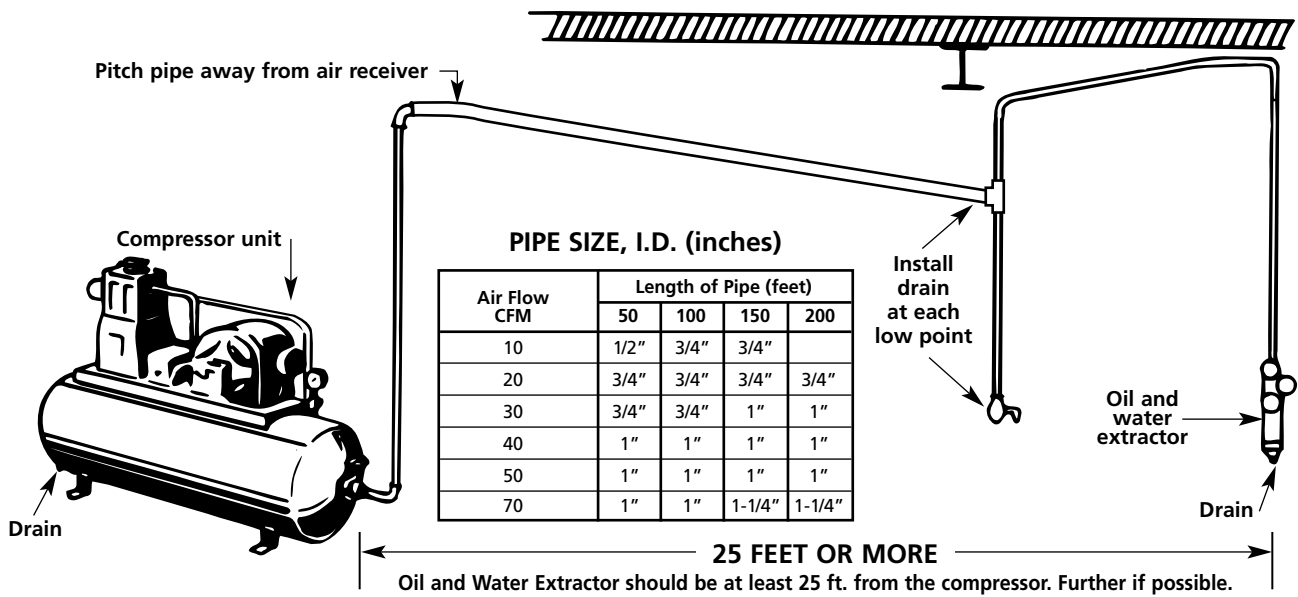

The oil and water extractor should not be mounted on or near the air compressor.

The temperature of air is greatly increased during compression. As the air cools down to room temperature, in the air line, on its way to the spray gun, the moisture contained in it condenses. Thus, for maximum effectiveness, the oil and water extractor should be mounted at some point in the air supply system where the temperature of the compressed air in the line is likely to be lowest.

Air lines must be properly drained.

Pitch all air lines away from the compressor so that condensed moisture can be drained off. Each low point in an air line acts as a water trap. Such points should be fitted with an easily accessible drain. See diagram above.

AIR PRESSURE

Air pressure at the gun is important.

Atomizing pressure must be set to allow for the drop in air pressure between the regulator and the spray gun.



Only 44 PSI

25 feet of 1/4" I.D. hose causes a drop of 16 PSI between the air supply and the gun.



Only 55 PSI

25 feet of 5/16" I.D. hose has a drop of only 5 PSI. For this reason we recommend the use of 5/16" hose.

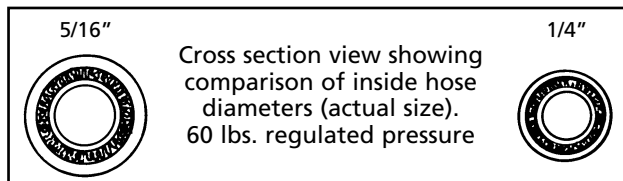

Binks oil and water extractor is important.

A Binks extractor serves a double purpose. It eliminates blistering and spotting by keeping air free from oil and water... and its precision air regulator makes possible perfect air pressure control at the gun.

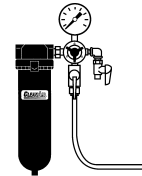

The best spray gun in the world will not operate efficiently without a good compressor and a good oil and water extractor. Model 86-621 is recommended.

If you are attempting to get a fine finish without the use of an oil and water extractor you will not succeed.

WARRANTY This product is covered by Binks' 1 Year Limited Warranty.

Binks Worldwide Sales and Service Listing: www.binks.com

ITW Industrial Finishing

Binks has authorized distributors throughout the world. For technical assistance or the distributor nearest you, see listing below.

U.S./Canada Technical Service Office:

195 Internationale Blvd., Glendale Heights, IL 60139
Toll-Free Telephone: 1-888-992-4657 (U.S.A. and Canada only)
Toll-Free Fax: 1-888-246-5732

ITW Automotive Refinishing

Binks has authorized distributors throughout the world. For equipment, parts and service, check the Yellow Pages under "Automotive Body Shop Equipment and Supplies." For technical assistance, see listing below.

U.S./Canada Customer Service Office:

1724 Indian Wood Circle, Suite J-K, Maumee, OH 43537
Toll-Free Telephone: 1-800-445-3988 (U.S.A. and Canada only)
Toll-Free Fax: 1-800-445-6643



An Illinois Tool Works Company

77-1153R-17 Revisions: (P2) Added warnings page.